

Assembling Panels with Sloping Top Rail

Step 1 - Assemble 19mm square bars into pool channel as per normal but do not tap the top pool channel down further than 5~10mm.

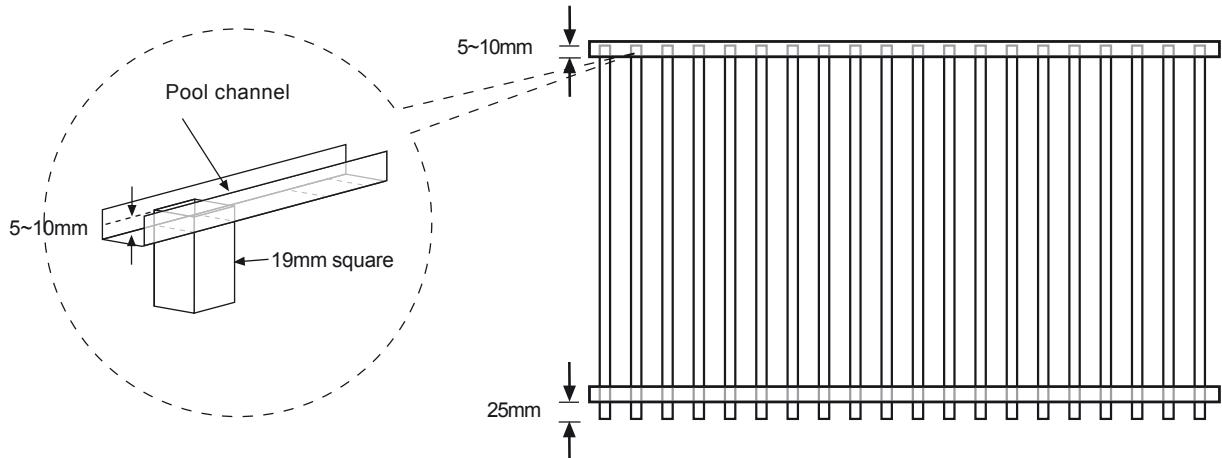

Step 2 - Now place threaded bars carefully onto two saw stools with timber between as specified in instruction sheet L, **step 1**

Ensure panel is square (Diagonal measurements are equal)

Step 3 - Lay 13mm angle supplied across bars to required angle. Tek screw this 13mm angle at each intersection point of the vertical bars for the full panel.

Step 4 - Now cut off the excess 19mm square bars from 10~20mm above the angle using a hacksaw. Then slide rails onto panel as per normal assembly instructions and complete assembly of panel.

